

ECONOMIC ENTITIES AND HISTORY OF ECONOMIC THINKING

Dalina Andrei¹

Abstract

This below paper focuses on the economic entity concept. Difficult to find that (part of) economic literature not dealing with economic entities and afferent issues. But there won't be the definition the paper's starting point – this, assumable as followed by a whole description then inclining to a rather didactic text attitude --, but, on the contrary, there will be what is supposed to come out previously of all definitions. Or, this will be the history of economic thinking and here that part of history ,giving birth' to micro- and macro-economics. And this will more precisely be about the JM Keynes' capital paper of 1936' focus that is what was called the ,Macro-Model'.

Keywords: economic entity, micro- economics macro-economics, firms, banks & banking system, State & Government, rest of the world, flows & stocks

JEL Classification: B12, B17, C00, D00, E00, H00

Let us repeat it: difficult to find that part of economic literature not dealing with economic entities and/or afferent issues [7]. Besides, an unwritten rule here is that all economic thinking context implying a name like that of John Maynard Keynes ought to be presumed, even worn as (at least) ,not simple' or, all the less, simplist. Let us just limit to this master's capital paper² and there will be found out that the current literature, including manuals of economics, rather stays ,stacked' around its coordinates when regarding the economic entities [1].

1. History of economic thinking: the ,birth' of *micro- and macro-economics*

Even a ,macro-model'³ limits to what a mathematical model is claimed to be – in its restricted sense, this last simplifies the reality and that, presumably, on all its components and facets. This will be obvious immediately below, but despite this the Keynes' Macromodel stays and survives in the currently update reality.

Another aspect in context is that ,the master' himself openly rejects all parentship upon macroeconomics, plus he indicates the two basic theories that had been his paper's references. These last were dating since at least one and a half centuries earlier. Never too easy for Keynes recognising that his classic adversaries at that time had once in the past been the true parents of macroeconomics and in his capital paper he fully took the opportunity to harshly combat their position(s) as much as his ,new' attitude⁴ was coming to be backed by the Great Depression's aftermath environment. We can assert that such a Keynes' ,revenge'⁵ might be punctually starting by rejecting his contribution's references in papers of Adam Smith, William Petty, David Ricardo, Robert Th. Malthus or even of the later Alfred Marshall⁶, in favour of the one of an old (the 18th century end) French economist like Jean Baptiste Say, with his ,supply making its own demand'⁷, the same with the ,firms-individuals' or ,closed economy' model – i.e. otherwise only good to be criticized in 1936.

¹ Ph.D, senior researcher, Economic Forecasting Institute of the Romanian Academy, Romania, dalinaandrei@yahoo.com.

² Keynes, J.M., *Théorie de l'Emploi, du Credit et de la Monnaie*, Paris, Dunod, 1936

³ i.e. the Keynes' one.

⁴ Not to be here omitted the also truth that Keynes had shared the classics' view before 1936.

⁵ As much as such a low word could ever be attributed to a great scholar like JM Keynes.

⁶ To whom JM Keynes owed at least some of the beginning of his career.

⁷ As usually sometimes, there are voices claiming that 'supply creating its own demand' was different than the Say's real view and that such expression would entirely belong to JM Keynes himself.

Moreover, Keynes goes even further into the historical past to one generation previous to JB Say and keeping on the French authors' affiliation – i.e. his other author reference was found in the person of François Quesnay: an Adam Smith's contemporary, not even a classic, but part of the older Physiocrats' thinking camp and the author of "*Tableau économique*", published in 1758, as a kind of ascendent of the nowadays 'Input-Output' model of W. Leontiev.

Shortly, Keynes couldn't deny the Quesnay-Say's ideas agreement on macroeconomics: the economic entities were the *firms* and *individuals* for both. The plea for macroeconomics as a self-developed system – i.e. against all ideas of artificial economic restrictions or dirigisme -- is the one that reeks of Keynes – i.e. that is for the classics all over and so Keynes proves more sensitive to the Quesnay's view side. All the more, the last contains, besides the two groups of economic entities, the *flows*, inevitably linking them to one-another and part of their whole activity. Let us have the simple¹ Quesnay's view in Diagram 1.

And then Keynes takes over the Quesnay's view and replies to, first by unifying diverse (physical) flows into *national income*(*Y*) flowing from firms to households and *consumption*(*C*) flowing back from households to firms – i.e. the automatic $Y=C$ equality yet belonging to François Quesnay(Diagram 2), then not being taken over by Keynes. And that was due to such a model – i.e. of flows --reasoning with the JB Say's markets' – i.e. of goods and of labour – equilibrium.

Back to Quesnay again, his merits equally remain on the aspect regarding *economic entities* – i.e. the author does here suggest the last's behavioural specificity and so diversity that extends from entities to afferent *flows* within the large macroeconomic picture(Andrei 2019a, pp.272-276).

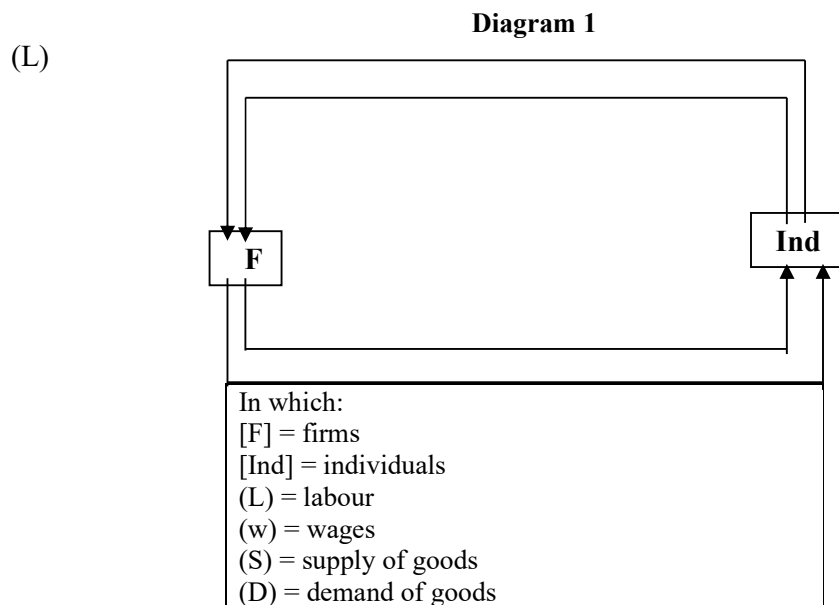

¹ Actually, simplified.

Diagram 2

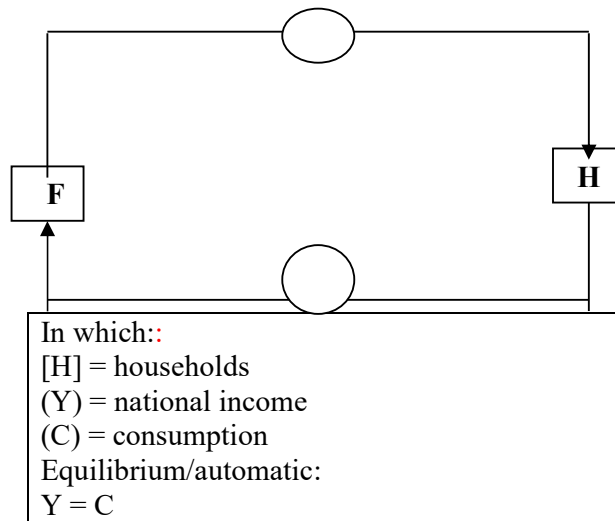

Shortly, Keynes goes on the *Macromodel's* analysis, concomitantly rejecting the Quesnay-Say basic equilibrium presumed and so the (good) result here coming then was the model's essential view transformation, actually here adding newly identified economic entities and flows between – i.e. to the existing firms [F] and households [H](Andrei 2019b), on the one hand, and national income(Y) and consumption (C), on the other. These new (groups of) economic entities are: the banks [B], State-Government [G] and rest of the world [W], each of them with a pair of additional flows (Diagram 3).

Diagram 3

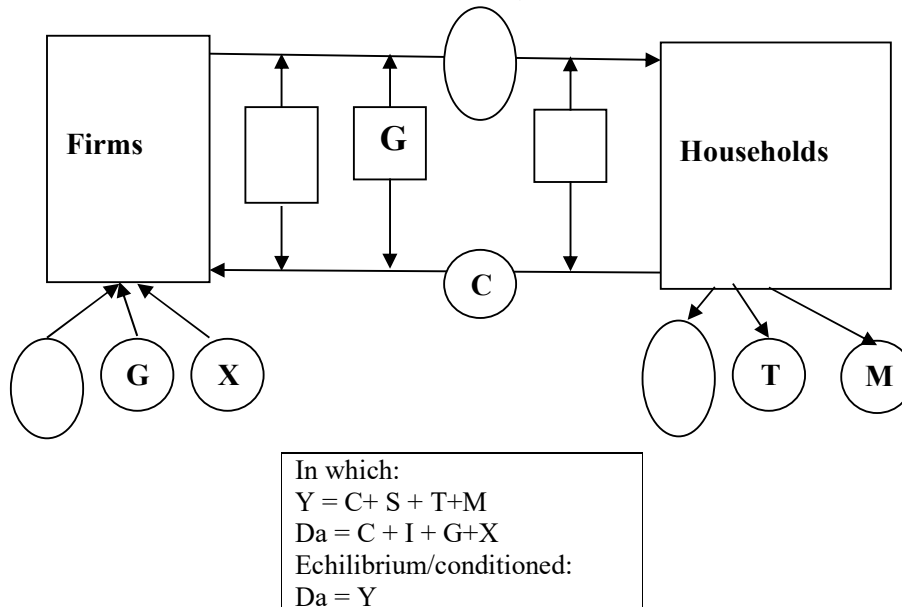

Basically, Keynes accepts that firms[F] pay wages to the households' members[H] and provide their goods produced to market – i.e. and this is *national income*(Y). Individuals/ households[H] receive the last, first for their *consumption* (C) – i.e. the same as in the Quesnay's view --, but then to consumption Keynes adds some alternatives – i.e.

individuals/households *save* (*S*) something of their income, pay *taxes* (*T*) and do access some *imports* (*M*) for the same consumption, here from a different market than the domestic one:

$$Y = C + S + T + M$$

On the firms[F] side – i.e. the left hand side of the above picture – they provide national income to households[H], but only basing on both market demand received from – i.e. the same as *consumption* (*C*), not viewed as the classic goods' destruction, but on the contrary, feeding the new(next short time-term) *national income* (*Y*)– and labour – i.e. here, more or less offset by *investments* (*I*) and *government spending* (*G*) --, *exports* (*X*) here added for the same above alternative market to the home one, as the new open economy expression:

$$C + I + G + X = AD$$

And here to be noticed the *aggregate demand* (*AD*), as the Keynesian alternative to *national income* (*Y*) in new circumstances of macro equilibrium – i.e. conditioned, as $Y = AD$ only when concomitantly $I=S$, $G=T$ and $X=M$ on the same short term. This is the way of the Keynesian type transforming the ancient Quesnay's view of macroeconomics.

Actually, macroeconomics (thinking) entering the Great Depression's aftermath here met a new and large debate between the classics' presumable *self regulating* capacity and the Keynes' expressed *need for dirigisme* – i.e. the origin of (macro)*economic policies* everysince -- of the (macroeconomic) system. Or, this debate stays the same today.

2. Primary conclusions

First of all, there is a kind of economic thinking pattern lying between *microeconomics* – i.e. the economic entity description – and *macroeconomics* – i.e. the same for national economy –, as there was in the case of tandem between the domestic and international markets – i.e. the same scale criterion. Since David Ricardo – i.e. the early 19th century – the international market had no definition in the absence of the similarly clear definition and understanding on the domestic market side; and conversely. Both nation and international entities do benefit of the same 'starting point', at least on the economics side.

Or, it is similar for *micro-macro*-economics: microeconomics do find the structural economic entities' behavioural diversity, while it is macroeconomics finding this last as singular factor of making entities work and even of keeping their sense of existence – i.e. as individually. Any individual firm/bank/insurance organization does exist only when macrosystem, with its all entities and flows between, is and remains in place; never without. From the other stand point, it is all economic entities shaping the (macro)economic system very together.

Second, economic entities are defined by their linkages with specific *flows* made either. Flows are as diverse as entities, e.g.: flows of capital, of money, of productions and production factors, of labour etc. – i.e. all kinds of matters and values. On the other hand, flows, as their whole, form the *economic circuit* – that is basing and shaping the macrosystem [6] (*Seminar „Agenții Economici”. Capitolul 3*, pp. 2-4). Then, judging on the common above Quesnay-Keynes model principle this circuit easy finds the equilibrium, where firms-households relink and on the contrary – i.e. here, for the equilibrium -- when/where more economic entity types get here involved.

Back to the above entities' and flows' diversity, there is to debate both about several understandings of this and even about 'several flow diversities'. Let us go back to the above Diagrams 2 and 3 and easily imagine the money flow as contrary to given arrows sense. Or this money flow so here reveals the other arrow sense flow as non-monetary, so material and that will be identified with a physical multiplicity of materials in movement. One of such diversity ideas might be found further on... back even towards the Quesnay view; another one imagining production, as individual flows – i.e. those flows cumulating individually as a diversity of other flows, those of the factors of production.

The next conclusion sees the economic entity in another perspective than the one above regarding its interaction with specific environment – i.e. the economic entity might be (why not?) a system, and economic system in itself. This is a whole, a self-contained one. This is a distinct factor of the economy. This identifies itself with an economic activity that is itself clearly defined and described. Plus, economic entity and its activity both stay out of all subordination – e.g. to other entities or to authorities of all kind.

Or this is a truth clearing the way for an ideology of systems – i.e. the whole economy is a system as much as all economic entities in. Besides, in a rather pragmatist view it doesn't belong to economic entities the one who does subordinate to other commands. On the contrary, the economic entity is that basic concept missed by that 'political economy' claimed by totalitarian pro-Marxian ideologies – i.e. the economic entity is always for that (free) economy overall basing on free initiative. And this is not ideology.

Last, but not least, the economic entity as that factor of economy chooses its activity of a long list as such eloquent for the nowadays economic diversity¹.

References

1. Agenții economici. Circuitul economic, <http://www.stiucum.com/economie/economie-general/Agentii-economici-circuitul-ec14433.php>
2. Agenții economici în economia de piață, <http://www.rasfoiesc.com/business/economie/agentii-economici-in-economia-42.php>
3. Andrei, LC (2019a): Economie. Ediția a treia. 2019. Editura Economică
4. Andrei, Dalina (2019b): Some Today Approach of the Household in the Economic Literature. Research in Economics and Management ISSN 2470-4407 (Print) ISSN 2470-4393 (Online) Vol. 4, No. 1, 2019 www.scholink.org/ojs/index.php/rem 32 Original Paper
5. Keynes, J.M., Théorie de l'Emploi, du Credit et de la Monnaie, Paris, Dunod, 1936
6. Seminar „Agenții Economici”. Capitolul 3. Biblioteca „Regie-Life” <https://biblioteca.regielive.ro/seminarii/drept/agentii-economici-179467.html>
7. Univ. N. Titulescu/Facultatea de Științe Sociale: Agenții Economici. Tipologie și caracteristici. Note de curs preluate de web-site: <http://www.creeaza.com/afaceri/economie/agentii-economici-tipologie-si889.php>

¹ There seems to be a problem of economics with separating what is from what are not economic activities. It is true, on the one hand, that the capacity of a topic equally deals with the extent of the object considered as its own. But on the other hand, the problem comes up when seeing the limits of the same object become less precise.